

## Building instructions for the racing MICRO MAGIC model boat, Order No. 2014

### Description of the model

The racing MICRO MAGIC has been developed to reflect progress in the MICRO MAGIC regatta scene. In its standard form the boat represents a modified version of the original model designed for the ambitious regatta skipper; it is intended to complement the earlier MICRO MAGIC, which has proved to be very popular. The racing MICRO MAGIC includes a carbon fibre rig with a slim 5 mm Ø mast, improved sails and a completely new set of high-quality plastic fittings. A new feature - unprecedented in a kit model - is the variable-position keel (fore-and-aft direction), which enables the operator to adjust the model very quickly to suit varying sailing conditions, and to satisfy the operator's personal preferences. The revised keel fin and rudder are of slightly reduced area and thinner profiles in order to reduce water resistance. The slightly heavier ballast bulb is also longer, resulting in enhanced directional stability. The boat is designed for an RC system consisting of fairly small, lightweight components, and the internal arrangement has been optimised with such a system in mind. An additional micro-servo can also be fitted to provide jib sheet trim control from the transmitter, so that the sail trim can be fine-tuned while the boat is on the water. The sail adjustment system has been designed for reduced friction, with a double control arm and return pulleys, with the result that a lighter servo can also be employed safely.

The shape of the bow and stern have been re-worked slightly to give the boat a more modern appearance, but the basic lines of the original hull have been left unchanged in order to stay within the German class rules.

### Specification

Overall length approx.	535 mm
Beam approx.	180 mm
Overall height approx.	980 mm
All-up weight approx.	850 g
Sail area approx.	1450 cm <sup>2</sup>

### Important safety notes

You have purchased a kit which can be assembled to produce a fully working RC model when fitted out with the appropriate accessories. As manufacturers, we at GRAUPNER are not in a position to influence the way you install, operate and maintain the model, nor the other components used in connection with the model. For this reason we are obliged to deny all liability for loss, damage or costs which are incurred due to the incompetent or incorrect use and operation of our products, or which are connected with such operation in any way. Unless otherwise prescribed by binding law, the obligation of the GRAUPNER company to pay compensation, regardless of the legal argument employed, is excluded. This includes personal injury, death, damage to buildings, loss of trade or turnover, interruption of business or other indirect or direct damages which are caused by the operation of the model.

Under all circumstances and in all cases the company's overall liability is limited to the amount which you actually paid for this model.

**The model is operated at the sole risk of the operator. To avoid injury to persons and damage to property please handle your model boat carefully and operate it conscientiously at all times.**

Before you run the boat for the first time it is important to check that your private third party insurance policy provides cover when you are operating model boats of this kind. If you are not sure, take out a special insurance policy designed to cover the risks of RC modelling.

These safety notes are important, and must be kept in a safe place. If you ever dispose of the model, be sure to pass them on to the new owner.

### Guarantee conditions

The guarantee covers replacement of any parts which can be shown to exhibit manufacturing faults or material defects within the guarantee period of 24 months from the initial date of purchase. No other claims will be considered. Cost of transport, packing and freight are payable by the purchaser. We accept no liability for damage in transit. When you send the product to GRAUPNER, or to the approved Service Centre for your country, you must include a clear and concise description of the fault together with the invoice showing the date of purchase. The guarantee is invalid if the component or model fails due to an accident, incompetent handling or incorrect usage.

### The following points are important and must be observed at all times:

- This model is not suitable for young persons under fourteen years of age.
- The keel ballast bulb is made of lead! This material is **toxic**, and must not be allowed to enter the body. Sanding dust and slivers of the metal are particularly dangerous, as they can easily be ingested. After working on the lead weight, clean the work place immediately, and wash your hands thoroughly. If possible wear gloves when handling this material.
- If you need to dispose of the lead weight at any time, be sure to take it to your local toxic waste collection point. It must **never** be discarded in the household refuse. If you are not sure where you can take scrap lead, ask your local authority for information.
- The projecting parts of the model may be sharp, and the aerials and masts may cause eye injuries.
- If the model is to be built by a youngster, a parent or guardian must monitor the assembly process, as tools and adhesives can be hazardous.
- Please operate the model **carefully** when there are persons or animals in the water; **always** keep a safe distance between the boat and man or beast.
- Never run your boat in a protected site, an animal or plant sanctuary or a site of special scientific interest (SSSI). Check with your local authority that the stretch of water you wish to use is suitable for model boats.
- Do **not** sail the vessel in salt water.
- Never run your boat in adverse conditions, e.g. rain, storm, strong wind (above Beaufort 4), choppy water or strong currents.
- As the model is propelled solely by the wind, it should only be sailed in wind strengths of 1 to 3 on the Beaufort scale (leaves moving in the wind). If the wind is stronger, the boat could heel severely and be impossible to control. Gusty conditions should also be avoided.
- The model requires a breeze in order to move, i.e. in flat calm conditions the boat will just remain stationary on the water. Please bear this in mind before sailing the model.
- Before you operate the boat, please check that the radio control system is working reliably.
- It is important to check the range of the radio control system: switch the radio control system on, hold the transmitter in your hands, and walk about 50 m away from the boat. All the radio-controlled functions should continue to work normally at this range.
- Ensure that the channel you intend to use is not already occupied by another modeller. Never run the boat if you are not certain that your channel is free.
- Note that other radio equipment and transmitting stations may cause serious interference to the model's receiving system. If possible, ensure that no such apparatus is in use in the vicinity while you are operating the boat.
- Switch the model's radio system off before carrying out any work on the boat.
- Dry cells and rechargeable batteries must never be short-circuited, nor allowed to come into direct contact with water.
- Remove all batteries from the model and the transmitter when you know you will not be using them in the near future.
- Do not subject the model to high levels of humidity, heat, cold or dirt.
- Secure the model and the transmitter when transporting them, as they may be seriously damaged if they are free to slide about.
- **Never** operate the model on moving water (e.g. a river), as it could easily be washed away downstream if the wind conditions change.
- If you have to **salvage** the model, take care **not to risk your own life or that of others**.
- Check regularly that the boat is completely watertight, as it may sink if too much water enters the hull. Check the model for damage before every run, and ensure that water cannot penetrate the hull.
- Allow the boat to dry out thoroughly after use.

### Care and maintenance

- Clean the model carefully after every run, and remove any water which gets inside the hull. If water gets into any of the RC components, dry them out and send them to your nearest GRAUPNER Service Centre for checking.
- Clean the model and the transmitter using suitable cleaning agents only. We recommend wiping with a lint-free cloth. **Never** use chemical cleaners, solvents, petrol, white spirit or similar.

### Notes on building the model

- This model is not intended for the beginner to modelling, and for this reason the instructions do not cover every single step of construction, as we assume that the experienced model builder will be familiar with these standard techniques.
- We recommend that you visit the Internet website [www.micromagic-rc-segeln.de](http://www.micromagic-rc-segeln.de) for the latest information on assembling and setting up the model.
- If you do not understand the technical terms relating to sailing boats, you can download a sketch showing the basic terminology from the Internet site mentioned above.
- Before you start building the boat, please take the time to study the plan and read right through the instructions, referring constantly to the Parts List. In general terms the instructions and parts list reflect the sequence of assembly.
- The laser-cut wooden components are retained in their sheets by small lugs. Cut them through from both sides using a sharp knife, then break the parts away from the waste material.
- All the laser-cut parts have a black outline caused by the cutting process. You can easily sand this off if you wish.
- The wooden internal parts for the hull are accurately pre-cut, but it is still important to trim them to match the shape of the hull and deck precisely. If the bulkheads are a tight fit, they will show through on the outside of the hull, so it is important to trim the parts as carefully and as accurately as you can.
- **TIP:** the rigging cord is easier to thread through small holes and openings if you first apply a drop of cyano to the end to harden it, then cut off the frayed extremity.
- Compare the laser-cut parts with the sketches at the end of these instructions to help you identify them and assign the part numbers.
- Wooden parts which have been coated with GLATTFIX sanding sealer cannot be glued satisfactorily using UHU acrylit or STABILIT express, so keep the sealer away from the joint areas. You should also avoid smearing excess adhesive onto the model's surfaces, as this will often prevent paint adhering properly. This applies in particular when you are gluing the vacuum-moulded plastic parts.
- Please bear in mind that many tools can be dangerous if misused or handled carelessly.
- Deploy the receiver aerial as high up in the hull as possible. Reception will be very poor if it is positioned below the waterline, and effective range will be greatly reduced.
- It is important to clean the joint surfaces carefully before gluing parts together. This is best done by sanding lightly, followed by wiping with a non-greasy liquid detergent or methylated spirit ("meths"). The same applies to all surfaces which are to be painted, as this improves the paint's adhesion considerably.
- Recommended adhesives for joining particular materials:

Material - material	Suitable adhesives
Metal - metal	Cyano-acrylate, UHU plus
ABS - wood	Cyano-acrylate, UHU acrylit
ABS - ABS	Cyano-acrylate, UHU acrylit, UHU plast spezial
ABS - metal	Cyano-acrylate, UHU acrylit
Wood - wood	Cyano-acrylate, UHU hart, white glue
Wood - metal	Stabilite express

Read the instructions supplied with the adhesives. Be sure to observe any special notes in the instructions regarding particular adhesives. If you are using acetone, methylated spirits or any other solvent as a cleaning agent, special safety measures are necessary. Read the instructions supplied with these materials.

## Assembly instructions

- Assemble the boatstand by fitting together the front support (part 1), the rear support (part 2) and the side panels (part 3); take care to glue the joints securely. Paint the finished stand when the glue is dry, and apply the self-adhesive foam tape (part 4) to the contact surfaces (not shown in the photo). The tape avoids scratches to the painted hull.
- Assemble the keel / mast socket (part 5). **IMPORTANT:** don't follow the outside shape of the vacuum-moulded parts when gluing the parts together. It is the inside area, which accepts the keel, which is important: the sides must be exactly parallel, otherwise the keel will not fit properly later.
- Glue a mast support reinforcement (part 6) on each side of the keel / mast socket on the underside, at the position of the semi-circular lugs.
- Glue together the two servo mount supports (part 7), and adjust the slot for the keel / mast socket so that the supports are an easy sliding fit on the socket. Glue this assembly to the keel / mast socket, aligned exactly as shown; the dimensions are stated on the plan. **NOTE:** one of the supports has a deeper slot for the keel / mast socket; this part should face down.
- Glue the completed keel / mast socket in the hull (part 8), taking care to position it accurately. Apply a fillet of UHU acrylit all round on the underside, to ensure that the socket is completely watertight.
- Sand back the bow reinforcement (part 9) until it is

an easy, snug fit in the tip of the bow. Glue the reinforcement in place securely using UHU acrylit. **NOTE:** take care to position the reinforcement accurately, as the central girder (part 25) must rest on it later.

- Glue one of the rudder bush reinforcements (part 10) over the hole for the rudder bush.
- Glue the two reinforcements for the sail servo (part 12) and the reinforcement for the jib trim servo (part 13) to the underside of the servo plate (part 11). Adjust the opening for the keel / mast socket so that the plate is a snug sliding fit over it, without compressing the socket. **NOTE:** the servo plate without the servo opening should be used if you

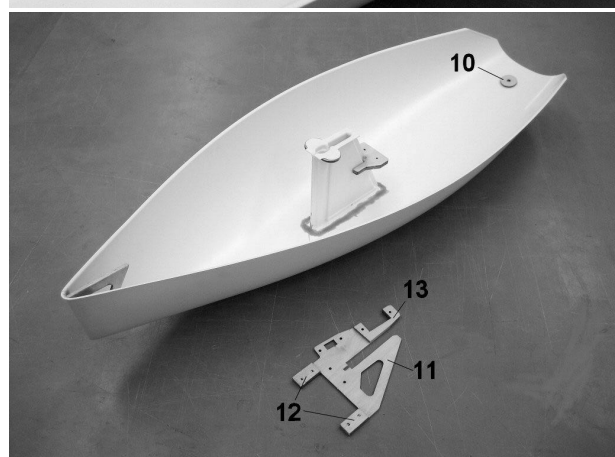
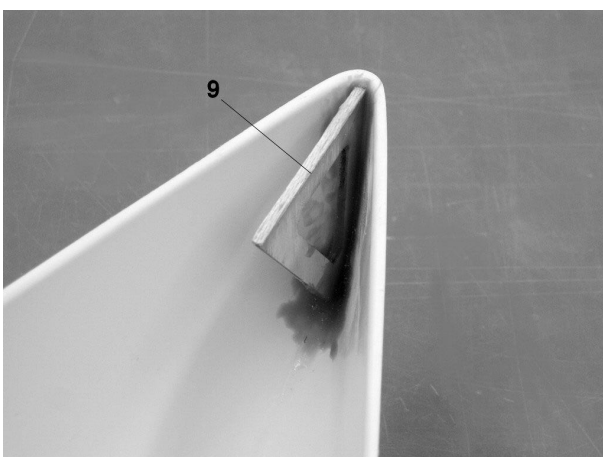
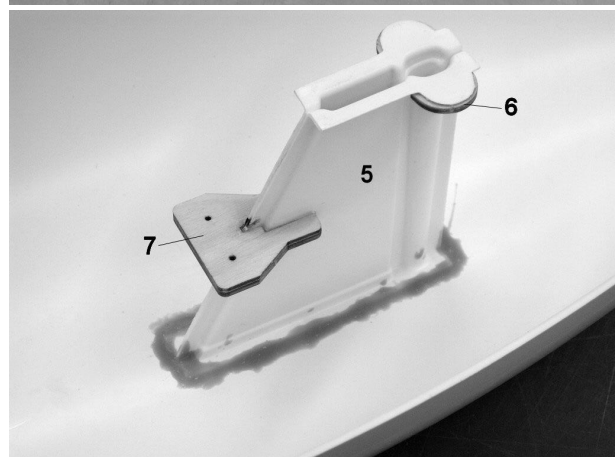
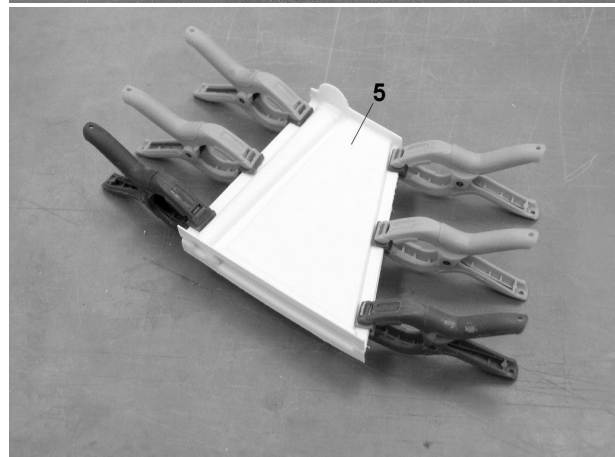
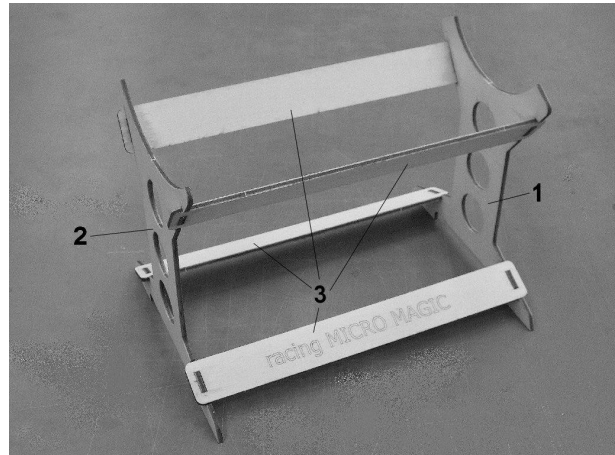

intend to install a sail servo other than those specified. Mark the outline of the servo opening and cut it out using a fretsaw. Position the opening so that the servo pivot axis will coincide with the hull centreline.

- All the bulkheads and reinforcements can now be glued under the deck (part 14). Taper the cockpit bulkhead (part 15) using a sanding block, so that it fits snugly in the channel in the deck. Glue the bulkhead in place permanently when you are satisfied. Glue the two reinforcements (parts 17 + 18) to the rudder servo plate (part 16), and insert the rudder servo plate assembly in the cockpit bulkhead. If the plate does not fit, adjust the slot in the bulkhead as required. Glue the plate permanently to the bulkhead when the fit is correct. **NOTE:** the semi-circular lug should rest snugly on the deck (cockpit). If there is a gap, fill it with UHU acrylit.
- Glue the second rudder bush reinforcement (part 10) over the hole for the rudder bush.
- Glue the central bulkhead (part 19) to the recess in the canopy opening. Check that the bulkhead is central and at right-angles to the surface of the deck.
- Glue the two lower shroud reinforcements (part 20) to the deck.
- Glue the four canopy latch reinforcements (part 21) at the bottom, flush with the recess in the opening. The position is shown on the plan, but you can change the location if you wish. **TIP:** mark the position of the reinforcements on the outside of the deck using a felt-tip pen. This avoids problems later when you are fitting the turnbuckles (part 47),

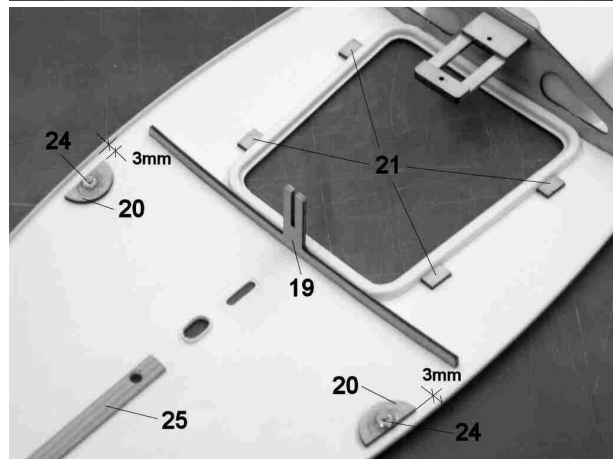
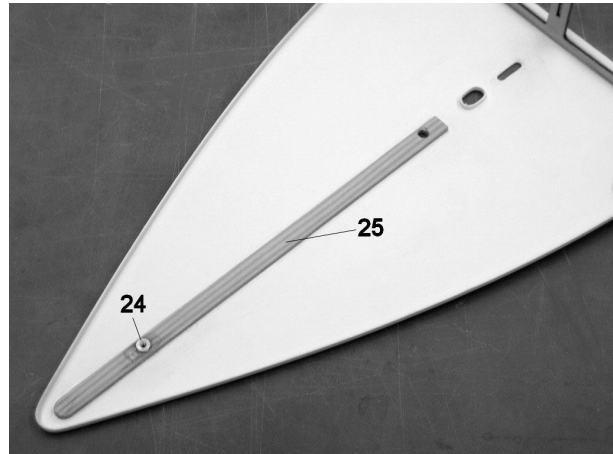

as their retaining screws have to be fitted into the reinforcements. **NOTE:** the canopy (part 55) is designed in such a way that it will normally be held securely by its fit in the deck. However, for competition work or harsh sailing conditions we would always recommend that you install the supplementary canopy latches.

- Glue the stern reinforcement (part 22) to the deck, keeping it central. Glue the stern side reinforcements (part 23) to the deck. **IMPORTANT:** remember to maintain the 3 mm gap between the plywood parts and the deck channel, as the hull has to be glued in that space (see photo). Sand the deck back flush with the wood.
- Sand one end of the central girder (part 25) to match the shape of the bow, cut it to a length of 210 mm, and glue it to the deck. **IMPORTANT:** ensure that the girder does not foul the keel / mast socket; it should end in front of this.
- The holes for the M2 captive nuts (part 24) can now be drilled; the positions are indicated by the markings on the deck. Drill a 2 mm Ø hole at each marked point, cutting through the deck and the reinforcement together. Now carefully open up the holes from the underside using a 4.2 mm Ø drill, cutting only through the wood, so that the cylindrical spigots of the M2 captive nuts (part 24) fit in them. The captive nuts can now be pressed into the wood. **TIP:** water pump pliers are very good for this, but remember to protect the ABS deck with a piece of scrap wood, otherwise the serrations of the plier jaws will mark the ABS. Secure the captive nuts with a drop of thin cyano first, then apply a fillet of UHU acrylit, so that they cannot possibly work loose. **IMPORTANT:** take care not to allow excess adhesive to run into the threaded part of the nuts. **NOTE:** if you accidentally drill right through the deck, you can glue the four 7 Ø / 2.1 Ø mm washers (supplied) on top; these will conceal the oversized holes.
- The next step is to cut the slot in the deck for the keel attachment: the length is indicated by the two marked points. The slot should be between 2.5 mm and 3 mm wide. **TIP:** drill 2.5 mm Ø holes in the deck

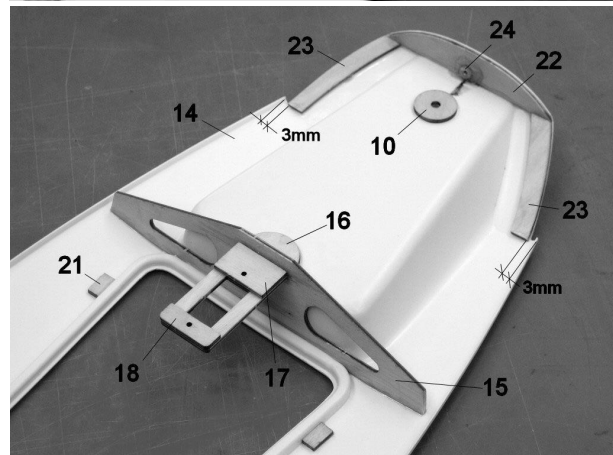

at the marked points, then form the slot by running a sharp knife between the two holes, working as accurately as you can. The slot should only be trimmed to final size when the deck and hull have finally been joined.

- The deck can now be glued to the hull: the first step is to check that the two parts are a snug fit together; if not, trim them carefully until they are an accurate fit. Apply UHU plus (e.g. Order No. 962) to the bow reinforcement (part 9) and the central girder (part 25) where the parts meet. Now apply plenty of UHU plast spezial to the edge of the deck - omitting the stern area - and join the parts without delay. **IMPORTANT:** ensure that neither the hull nor the deck is distorted when the parts are joined. Hold the hull and deck together using adhesive tape or rubber bands while the glue is hardening. However, don't apply too much pressure, or the hull will distort. Allow the glue to cure completely, then apply a little UHU plast spezial along the joint edges to fill any lurking gaps.
- Apply plenty of high-viscosity (thick) cyano-acrylate glue to the unglued gap at the stern. **TIP:** move the parts relative to each other to persuade the adhesive to work its way into the joint. Tape the stern area together while the cyano is hardening.
- The stern area can now be sanded flat; alternatively you can leave the hull projecting slightly beyond the deck.
- At this point you must check the hull / deck joint for leaks. You may need to run more cyano along the joint to fill any remaining gaps.
- The deck can now be stiffened by gluing the central bulkhead (part 19) to the keel / mast socket (part 5).
- The rudder bush (part 26) is glued in the hull next; you may need to trim the hole slightly. Position the rudder bush in the hull as shown on the plan, and glue it in place using thick cyano, forming a narrow fillet of adhesive round the bush at top and bottom. Allow the glue to cure completely, then sand back the underside flush with the hull. It is important that the gap between the rudder (part 27) and the surface of the hull is as small as possible. If the gap is not even, you may need to trim the top edge of the rudder blade to match the shape of the hull.
- Set the rudder servo (part 28) to centre from the transmitter, fit the output arm (part 29) on it, and install the servo in the servo plate using the retaining screws provided.
- Assemble the tiller (part 30) from the plastic lever, the collet and the M3 screw. Fit the tiller assembly on the rudder shaft and tighten the retaining screw.
- Drill two 2 mm Ø holes for the cable guides (part 31) in the positions shown, cut two 15 mm lengths from the snake inner sleeve provided, and glue them in the holes in the hull using cyano. **IMPORTANT:** ensure that the guides are angled correctly, so that the cables have as straight a run as possible when installed at a later stage.
- Drill two 4 mm Ø holes in the hull for the sheet

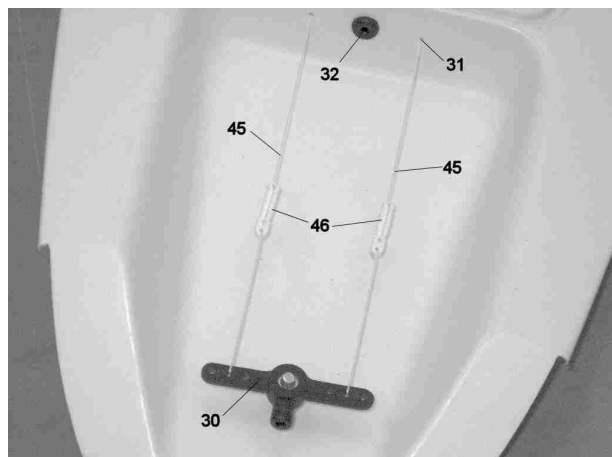
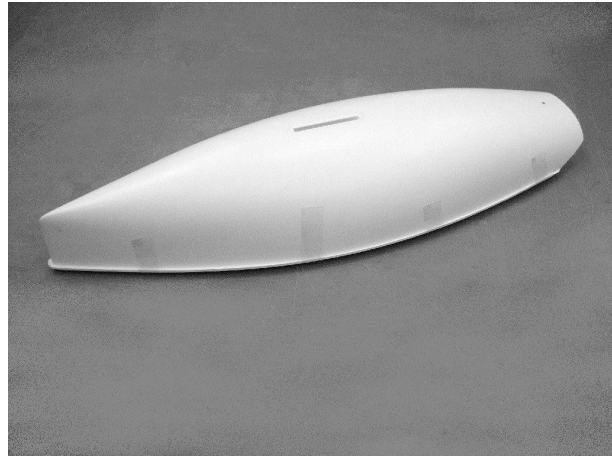

guides (part 32), in the positions shown on the plan. Glue the sheet guides in the holes.

- Fit two fillister-head screws (part 33) in the deck in the positions shown on the plan, leaving a gap of about 0.5 mm between the deck and the screw-heads. These screws are used later to secure the jib boom and the shrouds.
- Remove the ring-screw (part 34) from the end of the tensioners without the notch; only this one end features the right-hand M2 thread. Fit a washer (part 35) on each ring-screw, and screw them into the M2 captive nuts in the deck. **IMPORTANT:** take care not to push the screws into the captive nuts, otherwise they might come adrift inside the hull.
- Install the sail servo (part 36), the jib trim servo (part 37) and the switch (part 38) in the servo plate (part 11), using the retaining screws supplied with the servos. Shorten the output arm of the jib trim servo as shown on the plan. Screw the sail setting lever (part 39) to the output arm (part 29) using four fillister-head screws (part 33). Sand back the points of the screws so that they end flush with the underside of the sail setting lever.

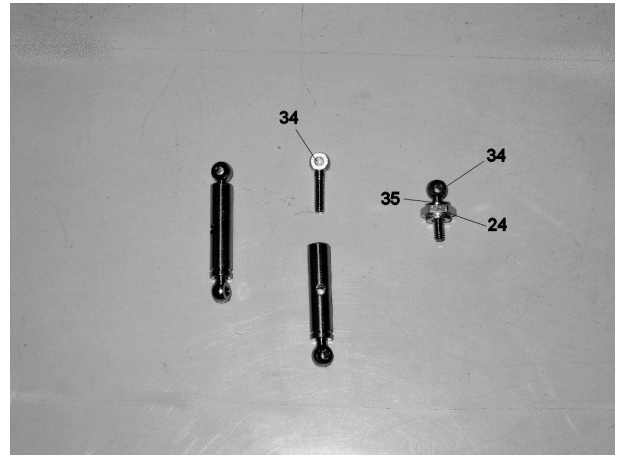

- Assemble the pulley blocks (part 40), ensuring that the pulleys swivel freely; you may need to sand off the rough edges from the injection-moulded parts. **NOTE:** the pulley blocks are made of a special low-friction plastic. Screw the completed pulley blocks to the servo setting lever using fillister-head screws (part 33). Note that the flat plate of the pulley blocks must rest on the lever. **NOTE:** the pulley blocks should be fixed in place; they should not rotate with the pulleys.
- Thread the jib sheet (part 42) through the sheet guide into the hull from the outside. Run the sheet past the right-hand side of the keel / mast socket, thread it through the pulley block and tie it to the servo arm on the jib trim servo. **TIP:** secure the knot with a drop of cyano. **TIP:** the jib sheet could easily disappear into the hull as you continue to work on the hull, so tie a toothpick or similar to the exposed end to prevent this. **NOTE:** if you don't wish to use a jib trim servo, simply tie the end of the jib sheet permanently to the rear fixing hole for the jib trim servo.

- Screw the servo plate to the servo mount support inside the hull using two fillister-head screws (part 41) and two washers (part 43) (in the interests of clarity the photo shows the hull without the deck fitted).
- Drill a 1.5 mm Ø hole to the left of the rudder servo, and tie the end of the mainsail sheet (part 44) to it permanently. Run the sheet through the pulley block and then through the sheet guide.
- Tie the two rudder steering cables (part 45) to the rudder servo output arm, and thread them through the cable guides. Pass the steering cables through the tiller and then through the tensioner (part 46). The method of connecting the tensioners is shown on the plan. Ensure that both tensioners are at approximately the same position.

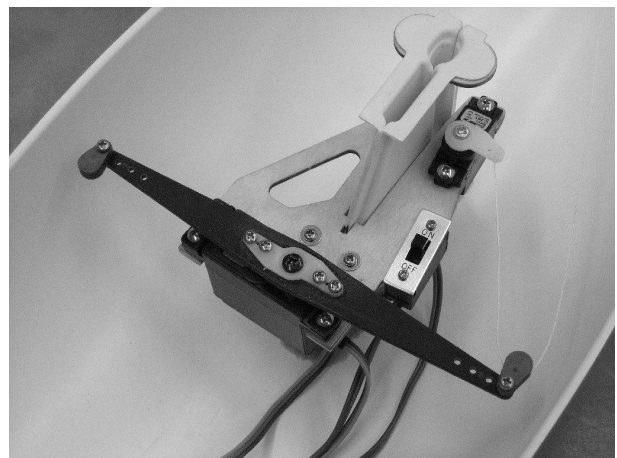

- Fix the four turnbuckles (part 47) in place using one fillister-head screw (part 33) each. **IMPORTANT:** ensure that the turnbuckles are adjacent to the channel in the deck when in the open position.
- Fit the keel (part 48) in the keel / mast socket using the appropriate adaptors (part 49). Trim the slot gradually until there is space for the keel retaining screws at all three positions. **TIP:** you may have to sand back the tongue of the keel and the adaptors in order to fit them in the keel / mast socket. **NOTE:** the keel is always used in conjunction with the adaptor set, which permits three keel positions. Adaptor (B) is used in order to position the keel towards the bow; adaptor (H) is fitted for the stern position, and both adaptors (M) are used to obtain the central keel position.
- The keel ballast bulb (part 50) is a sand-casting; for this reason the surface is not smooth, and may contain traces of sand. This must be filed off before the bulb is glued to the keel. **IMPORTANT:** lead is toxic. Always use gloves when handling the material, take great care to sweep away metal particles and filings immediately, and dispose off them in the appropriate way. It must not be ingested by man or beast!
- Fix the keel to the hull in the centre position, then place the model in the boatstand, parallel to the design waterline. Now hold the keel bulb against the underside of the keel: the ballast bulb should lie parallel to the

waterline, or inclined slightly upward towards the bow. **IMPORTANT:** it must not hang down. When you have obtained this position, glue the bulb to the keel using UHU acrylit or thick cyano. Allow the adhesive to cure, then cut two 1.5 mm Ø retaining pins (part 51) from the steel wire supplied, and pass them through the keel bulb and the keel to retain it.

- If you do not wish to use the keel bulb fairings, you should finish the keel using the following procedure: file the surface of the bulb as even, smooth and symmetrical as possible, and fill any remaining holes (e.g. using Order No. 924). Sand the filler back flush when hard. **NOTE:** the smoother the surface of the keel bulb, the lower the water resistance; careful work pays dividends here.
- Alternatively you can fit the keel bulb fairings (part 52). In this case you must sand away the lead bulb until the shells are a snug fit round it.
- Screw the keel to the hull using a washer (part 43) and the retaining nut (part 53); this holds the hull in a more stable position in the boatstand for the following stages.
- The rubber gasket (part 54) is glued in the canopy (part 55) using cyano. Don't cut the cord to final length until you are just about to join the ends.
- To complete the mast (part 56) you require the aluminium mast sleeve (part 57) and the hardwood dowel mast base (part 58). Sand the hardwood dowel until it is an easy sliding fit inside the mast, then glue it in the end of the carbon fibre tube. Sand the end flat, and round off the end slightly. Cut the aluminium mast sleeve to a length of 115 mm, and insert it in the mast opening.
- Slide the main boom bracket (part 59) and the mast plate (part 60) down over the mast sleeve until they rest on the deck. Check that everything is central, then fix the mast plate to the deck using fillister-head screws (part 33).
- Assemble the main boom swivel bracket (part 61), the washer (part 35) and the swivel axle (part 62), and check that the axle rotates very freely; if not, sand it to ease the fit.
- Glue the main boom (part 64) in the main boom sleeve (part 63). Screw the clamp nut (part 66) into the depressor (part 65). **TIP:** the correct thread is on the end with the notch. Push a large annular clamp (part 67) onto the main boom, fit one end of the depressor into the annular clamp and secure it with a retaining screw (part 68). Don't tighten the screw fully at this stage; it must be possible to adjust the position of the annular clamp on the boom.
- Screw the main boom to the main boom swivel bracket using two screws (part 68) and two retaining nuts (part 69).
- Fit the jib hanger (part 70) on the mast and glue it in place at a point about 95 mm from the top of the mast. The masthead fitting (part 71) can now be glued to the top of the mast. **IMPORTANT:** check that the masthead fitting is exactly in line with the jib hanger.
- Cut the backstay (part 72) from the white polyester cord supplied. Cut a piece from the large loop of one wire hook (part 73), as shown in the drawing, and apply a drop of cyano to the point where the two loops

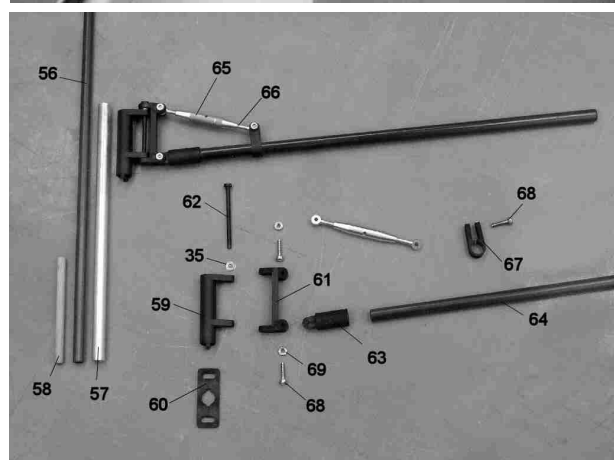
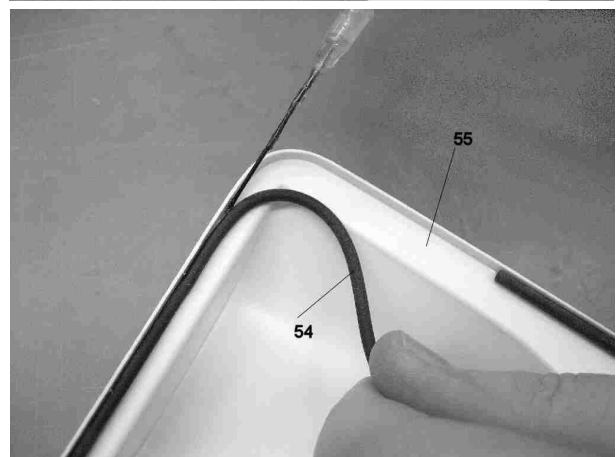
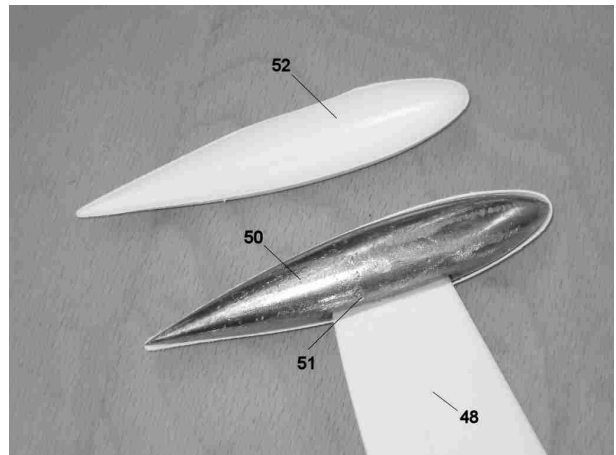
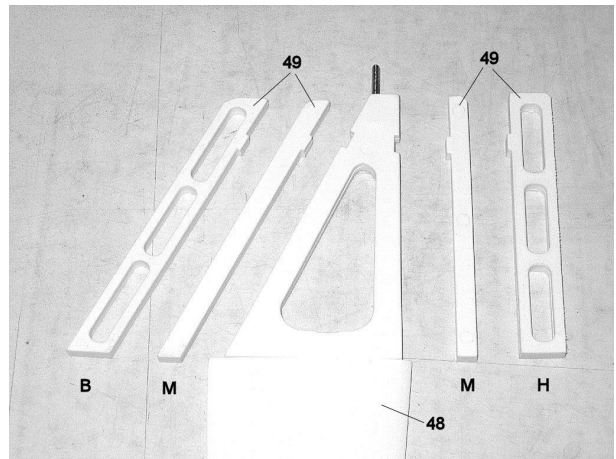

meet. **NOTE:** this ensures that the cord will not slip out of the loop. Tie the cord to the masthead, and run it through the small loop of the wire hook. Connect this to the ring-screw (part 34), thread the cord through a tensioner (part 46) and tie the end as shown. Adjust the tensioner to place the backstay under light tension.

- Tie the shrouds (part 74) to the inner hole of the jib hanger, leaving both ends of the cord approximately the same length. Make up two wire hooks as described earlier. Thread one of the cord ends through the small loop of the hook, and connect the large loop of the hook to the ring-screw. Slip the cord through a tensioner, then loop it around the fillister-head screw (part 33) in the deck and tie it to the tensioner again. Repeat the procedure with the shroud on the other side of the boat. Place the shrouds until light tension, so that the mast stands up straight.
- Rub the black stickers firmly onto the sails using a scrap piece of wood. Heat a needle or pin (caution: burn hazard!) and use it to pierce 1 mm Ø holes in the sail at the positions shown. The hole in the clew must be opened up to 2 mm Ø. The position of the holes is shown on the plan. **NOTE:** the hot needle melts the sail material cleanly, and prevents it fraying.
- Glue the carbon fibre sail battens (part 76) to the sail following the dimensions stated on the plan. The ends of the battens must be secured using the circular stickers (part 77) to prevent them coming loose. Apply the stickers centrally round the leech (trailing edge) of the sail.
- Tie the mainsail luff stretcher (part 78) securely to the throat of the sail. Tie the mainsail halyard (part 79) to the headboard (top corner) of the mainsail, and slip the halyard through the hole in the masthead fitting. Position the cord in such a way that the mainsail is located about 4 mm above the main boom swivel bracket, and tie it to the masthead fitting. Slip the cord of the luff stretcher through the two holes in the main boom bracket (part 59), run it through a tensioner (part 46), wrap the cord round the ring-screw, and tie the end to the tensioner again. Adjust the tensioner to place the mainsail under light tension.
- Fit the mast rings (part 80) over the mast and through the sail.
- Cut the sliding sleeve (part 81) from the snake outer sleeve. Slip one large collet (part 82) onto the main boom, fit the sliding sleeve into the collet, and secure it with a retaining screw (part 68). Slide the collet into position, and tighten the screw to secure it.
- Slide another large collet (part 82) onto the main boom, slip the clew of the sail between the clamp jaws and fit a retaining screw (part 68) to secure it. Ensure that the sail is under tension, and is able to move on the screw shank.
- Run the main sheet (part 44) through the sliding sleeve and into the collet. Press one large collet (part 82) over the main boom. Set the sail setting servo to the position at which the sails are close-hauled, then run the sheet through the holes in the collet and secure the sheet with a knot, as shown on the plan.

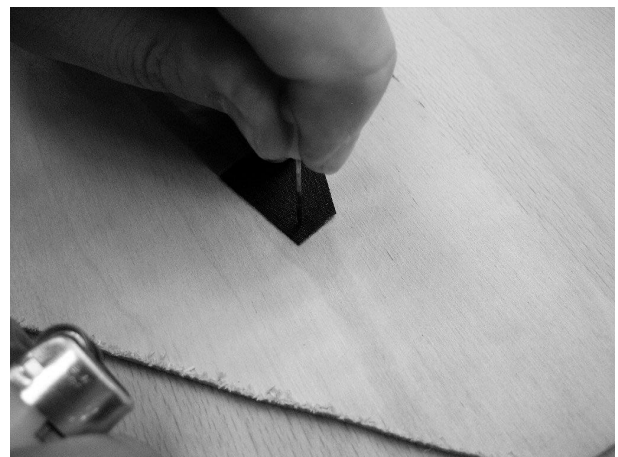
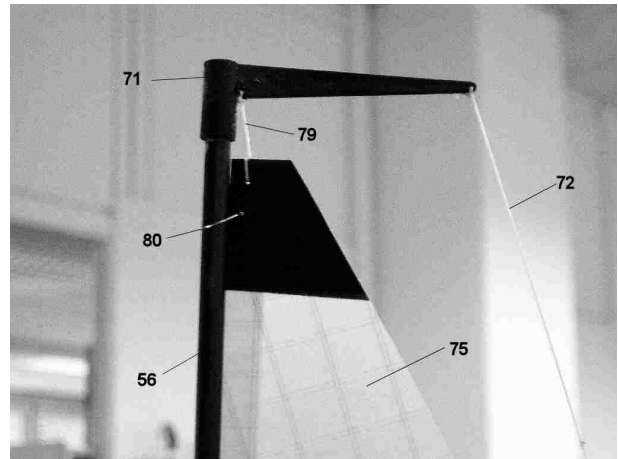
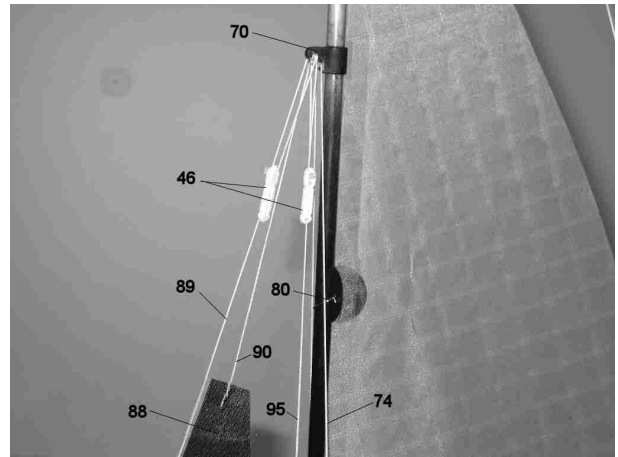

**IMPORTANT:** there must be sufficient travel for sheet adjustment; the correct position is central between

**GRAUPNER GmbH & Co. KG D-73230 KIRCHHEIM/TECK GERMANY #0057088**

the two collets.

- Glue the two end-caps (parts 84 + 85) to the jib boom (part 83). **IMPORTANT:** ensure that the two small holes in the caps are on the same side, and are lined up in the same plane. Glue the retaining pin in the hole in the cap with a drop of cyano, leaving it projecting by about 11 mm. The jib counterweight (part 87) can now be glued to the pin using UHU alleskleber (for a non-permanent joint). **IMPORTANT:** there should be a gap of about 1 mm between the counterweight and the cap.
- Pierce the holes in the jib (part 88) at the marked points, as previously described for the mainsail. The hole in the clew for the small annular clamp must again be opened up to 2 mm Ø.
- Slip the forestay (part 89) through the loops in the luff of the jib. **TIP:** apply a drop of thin cyano to the end of the cord over a length of at least 25 mm; this stiffens the cord, and makes it easier to slip it through the loop.
- Tie the jib halyard (part 90) to the headboard (top corner) of the sail. Tie the luff stretcher (part 91) to the throat of the sail at the bottom.
- Attach the small annular clamp (part 92) to the jib boom, fit the sail between the jaws of the clamp, and secure the sail with the retaining screw (part 68).
- Fit the luff stretcher through the hole in the jib end-cap (part 85). Fit a small collet (part 93) on the jib boom. Set the sail setting servo to the position at which the sails are close-hauled, then run the sheet through the holes in the collet and tie the end of the jib sheet as described for the main sheet. **IMPORTANT:** there must be sufficient travel for sheet adjustment; use the position indicated on the plan if possible. Place the collet under tension, so that the foot of the sail is parallel to the jib boom.
- Tie the forestay round the retaining pin (part 86). Tie the jib halyard to the outer hole in the jib hanger (part 70). **IMPORTANT:** the feet of the two sails should be exactly in line once the rigging is complete.
- Run the cord of the forestay through a tensioner (part 46), then through the outer hole in the jib hanger. Thread it through the tensioner again, then secure the cord with a knot.
- Fit a small collet (part 93) on the jib boom. Tie the jib retainer (part 94) to the collet, as described for the sheet. Make a wire hook (part 73) as described previously, connect the hook to the ring-screw, and run the cord of the jib retainer through the small eye of the hook. Pass the cord through a tensioner (part 46), loop it round the fillister-head screw in the deck (part 33) and tie the cord to the tensioner again. Place the jib retainer under light tension. The position of the jib should be adjusted by moving the collet along the jib boom until the jib counterweight is located just aft of the tip of the bow.
- Run the jib sheet (part 42) through the large hole in the jib boom end-cap (part 84). Fit a small collet (part 93) on the jib boom, run the jib sheet through the holes and tie it as described for the main sheet. **IMPORTANT:** there must be sufficient travel for sheet adjustment; about 30 mm to the small collet is a good starting point.
- Tie the topping lift (part 95) to the jib end-cap (part 84). Run the cord of the topping lift through a tensioner (part 46), then through the outer hole in the jib hanger (part 70), and finally tie the cord to the tensioner again. The topping lift should be only be under light tension, i.e. it must not pull the jib out of shape.

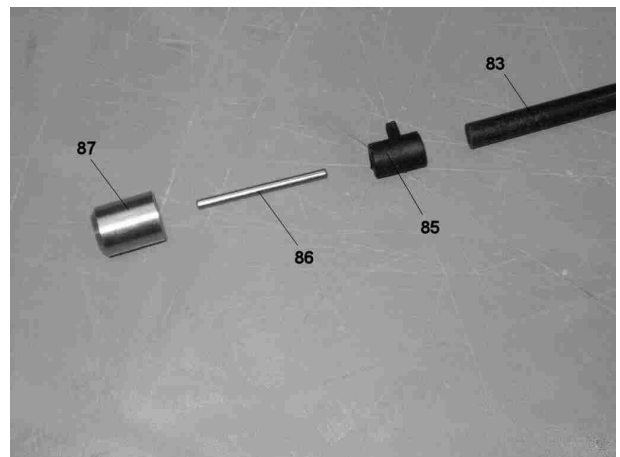
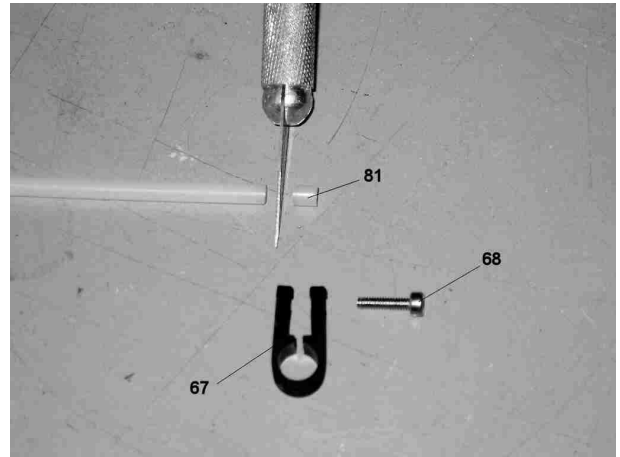

## Painting

- We recommend that you ask your local model shop (or specialist paint supplier) for advice on the best types of paint to use.
- Use ONLY paints of the same type, made by the same manufacturer, otherwise they may react with each other; dissolving the earlier coats or producing unsightly bubbles. **Caution:** Lexan paints are only compatible with each other; they must never be used in combination with other types or paint or primer.
- To ensure that the paint adheres well, it is essential to sand the surfaces with fine wet-and-dry paper (600-grit or 800-grit), then de-grease them using a non-greasy cleaning agent or white spirit. Try not to touch the cleaned surfaces again before painting, as your skin will just apply new grease to the surface.
- Do bear in mind that parts glued to painted surfaces can only adhere as well as the paint sticks to the model, i.e. such parts are often knocked off, tearing the paint from the model at the same time. Parts which are exposed and vulnerable should be glued directly to the sub-surface, i.e. the paint should be scraped off beforehand.
- Apply several coats of sanding sealer (e.g. GLATTFIX, Order No. 207) or clear lacquer (e.g. HYDRO-AEROFIX, Order No. 926.1) to all the wooden parts to prevent them absorbing water.
- When spraying paint, take care to mask off all areas which are not to be coloured. Seal all holes, as the fine mist of paint will find its way into any opening, no matter how small.
- Read and observe the instructions supplied by the paint manufacturer.

## Colour scheme

The recommended colours are stated below with their RAL numbers, to ensure that you will be able to select the correct hues. Armed with this information, any paint supplier will be able to produce the right colours for you. Let your specialist paint supplier or advisor know what you intend to use the paints for, as this will help him select the correct type. We always recommend synthetic enamels.

The colour RAL 9016 (transport white) is the ideal base colour for the model, as the decals are designed to be applied to a white surface. However, there is no reason why you should not paint the boat in any colour scheme you like.

## Applying the decals

Cut out the individual decals neatly using a pair of sharp scissors, leaving as little margin round them as possible. They should be applied to the model's surface once painting is complete; all traces of dust must be removed beforehand. To apply the large hull decal neatly, cut it out leaving virtually no margin, lay it on the hull without removing the backing film, and move it carefully into exact position. Fix one end of the decal with a strip of tape, then peel off the backing film in stages, rubbing the decal down onto the hull as you do so. An alternative method is to cut the large decal into its separate colour areas, as these are easier to apply neatly. The other decals can be positioned as shown in the kit box illustration, or applied in an arrangement of your choice.

## Sailing

Sailing a model yacht is not difficult once you are familiar with the inter-action between the wind direction, the boat's heading and the appropriate sail settings. Before you sail the model for the first time, we recommend that you read all you can on the theory of sailing, e.g. by reading one of the many books on the subject. The following section just provides a short, basic introduction to the subject.

### The various points of sailing (see sketch; specialist terms are printed in *Italics*)

A sailing boat can never sail directly into wind (black arrow (W)). In the 90° sector (dark grey area) the sails will always flutter (*shiver*), and generate no forward thrust. Only when the boat bears away to about 45° off the wind direction will it start to pick up speed with the sails close-hauled (transition from dark grey area to light grey area (2a) to (2b)). This course is termed *luffing*. A sailing boat can only make headway into the wind on this course and with the sails close-hauled; the procedure is known as *tacking*, and involves sailing in a zig-zag pattern: for a while on the *port tack* (mainsail on the left-hand (port) side of the boat (2a)), then, after going about (the boat's bow turns through the wind, from position (2a) via (1) to (2b)), for a while on the *starboard tack* (mainsail on the right-hand (starboard) side of the boat (2b)), etc. Fast, efficient tacking with a sailing boat demands a good eye and considerable manual skill, and ranks as the true art of sailing.

The other courses are not so demanding. If the wind is blowing from the side, the sails are slackened (*paid out*) just to the point where they no longer shiver, i.e. around 30° to 45° relative to the boat's longitudinal axis.

This course is known as *sailing with wind abeam* ((3a) wind abeam on the port bow / (3b) wind abeam on the starboard bow).

If the boat bears away even further (*bearing away*: the boat turns away from the wind, i.e. the stern turns increasingly in the direction of the wind (II) / *luffing*: the boat's bow turns increasingly towards the direction of the wind (I), ending up on a course *with free wind*, where the sails are paid out to about 60° to the boat's centreline (4a / 4b). The boat only attains its maximum speed on these two headings.

If the boat is sailing directly away from the wind (downwind), we speak of *running before the wind*. On this course the sails should be paid out as far as possible (approx. 90° to the boat's centreline). Differential pressure conditions on the sails cause the jib to turn to the opposite side to the mainsail by itself, but this situation can also be generated deliberately by small rudder / course corrections. If the wind is or becomes too strong, the bow of a sailing boat can very easily be pushed under the water.

If the boat is sailing with free wind, is brought into a position before the wind using the rudder (*bearing away*), and is then steered back to a free wind heading using the rudder (approximately at right-angles to the former course with free wind), the boat is said to have performed a *gybe*. Gybing is complete when the main boom, paid out a long way, swings from one side of the boat to the other.

### Steering characteristics / Sailing characteristics

Variations in wind pressure make it difficult for a performance-orientated sailing boat to maintain its course by itself; gusts of wind may cause it to luff up by itself, i.e. turn into the wind to a greater or lesser extent. This can be prevented by slightly paying out the sails in good time, and also by applying slight opposite rudder if necessary, until the gust is past. If the boat should bear away, the sails should be paid out at the same time as the necessary corrective rudder movement is applied. Otherwise, in fairly strong winds the boat will tend simply to continue stubbornly in a straight line, ignoring the corrective rudder commands. Please note that any sailing boat will turn uncontrollably into the wind if the breeze is too powerful. This means that the sail area is too

Segel-Kursskizze

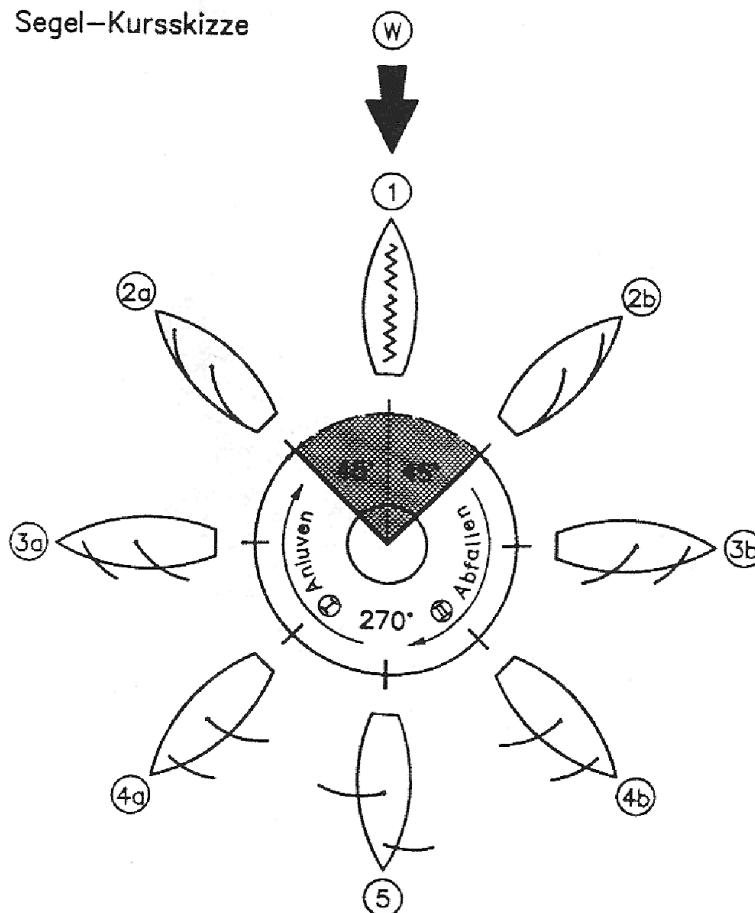

great; if there is no alternative smaller sail suit available, sailing is not possible in these conditions.

### Sail trim

The foresail of a yacht should always be slightly more open than the mainsail when close-hauled (mainsail around 2° midships: foresail about 10° to 15° close-hauled) so that the airflow from the foresail is directed onto the rear face of the mainsail, rather than being deflected into the front of it. The difference required varies according to the wind and weather, and can be adjusted on the racing MICRO MAGIC by altering the sheet clamps, either on the main boom or the jib boom.

If the boat does not maintain its course in a constant light wind and at a slight angle (*heel*) when luffing, then the trim of the rig is not correct, i.e. the centre of pressure of the whole sail area needs to be altered. In the case of the racing MICRO MAGIC this is achieved typically by adjusting the mast rake (inclination):

Situation / Behaviour	Solution / Adjustment
<i>Windward tendency</i> (the boat tends to turn into the wind by itself (it <i>luffs up</i> ).	The mast is raked too far back, and needs to be tilted forward (loosen backstay, loosen mast trimmer, tighten forestay / jib halyard).
<i>Leeward tendency</i> (the boat tends to turn away from the wind by itself (it <i>bears away</i> ).	The mast is raked too far forward, and needs to be tilted further back.

Caution: a boat's tendency to turn into or away from the wind is also affected by the sail settings; for instance, if the mainsail is set too tight by the kicking strap, or if the foresail is set too close-hauled or too far open.

In general terms sailing boats offer their maximum performance if they have a slight windward tendency. The optimum setting can only be established by experimenting; please bear in mind that it also varies according to the weather conditions.

### Maiden run

Wait for a day with optimum wind conditions, and seek out a stretch of water where you can easily salvage the model. Charge up the batteries, and check the model's working systems. Ensure that all parts are securely attached. Now you are ready for the boat's maiden run. Be cautious at first, and take your time to get used to the boat's sailing characteristics and handling. Don't sail the model too far from the bank initially.

All of us at GRAUPNER hope you have many hours of pleasure building and running your racing MICRO MAGIC.

## Parts List

No.	Description	No. off	Material	Size in mm
1	Front support plate (boatstand)	1	Plywood	4 mm, laser-cut
2	Rear support plate (boatstand)	1	Plywood	4 mm, laser-cut
3	Side panel (boatstand)	4	Plywood	4 mm, laser-cut
4	Protective stand lining material	1	Self-adhesive foam tape	Cut lengths to suit
5	Keel / mast socket	2	ABS	Vac.-moulded, CNC-trimmed
6	Mast support reinforcement	2	Plywood	2 mm, laser-cut
7	Servo mount support	2	Plywood	2 mm, laser-cut
8	Hull	1	ABS	Vac.-moulded, CNC-trimmed
9	Bow reinforcement	1	Plywood	2 mm, laser-cut
10	Rudder bush reinforcement	2	Plywood	2 mm, laser-cut
11	Servo plate	1	Plywood	2 mm, laser-cut
12	Sail servo reinforcement	2	Plywood	2 mm, laser-cut
13	Jib trim servo reinforcement	1	Plywood	2 mm, laser-cut
14	Deck	1	ABS	Vac.-moulded, CNC-trimmed
15	Cockpit bulkhead	1	Plywood	2 mm, laser-cut
16	Rudder servo plate	1	Plywood	2 mm, laser-cut
17	Rudder servo reinforcement, large	1	Plywood	2 mm, laser-cut
18	Rudder servo reinforcement, small	1	Plywood	2 mm, laser-cut
19	Central bulkhead	1	Plywood	2 mm, laser-cut
20	Shroud reinforcement	2	Plywood	2 mm, laser-cut
21	Canopy latch reinforcement	4	Plywood	2 mm, laser-cut
22	Stern reinforcement	1	Plywood	2 mm, laser-cut
23	Stern side reinforcement	2	Plywood	2 mm, laser-cut
24	Captive nut	4	Metal	M2
25	Central girder	1	Spruce strip	3 x 8 x 210 mm
26	Rudder bush	1	Brass tube	4 Ø x 3.1 Ø x 30 mm
27	Rudder	1	Plastic	Ready made
28	Rudder servo	1	Order No. 5125.LOSE	Ready made
29	Rudder servo output arm	2	Order No. 3941.50	Ready made
30	Tiller	1	Plastic	Ready made
31	Cable guide	2	Snake inner sleeve	2 Ø x 0.8 x 15 mm
32	Sheet guide	2	Plastic	Ready made
33	Fillister-head screw	14	Stainless steel	2.2 Ø x 6.5 mm
34	Ring-screw	4	Nickel-plated brass	3.8 Ø x 1.5 Ø x 11 mm
35	Washer	5	Nickel-plated brass	4.5 Ø x 2.2 Ø x 0.5 mm
36	Sail-setting servo	1	Order No. 4103.LOSE	Ready made
37	Jib trim servo	1	Order No. 5125.LOSE	Ready made
38	Switch	1	Order No. 3934.1	Ready made
39	Sail-setting lever	1	Plastic	Ready made
40	Pulley block	2	Plastic	Ready made
41	Fillister-head screw	2	Stainless steel	2.2 Ø x 9.5 mm
42	Jib sheet	1	Polyester cord	0.4 Ø x 500 mm
43	Washer	3	Nickel-plated brass	Ready made
44	Mainsail sheet	1	Polyester cord	0.4 Ø x 500 mm
45	Rudder steering cable	2	Polyester cord	0.4 Ø x 300 mm
46	Tensioner	9	Plastic	Ready made
47	Turnbuckle	4	Plastic	Ready made
48	Keel	1	Plastic	Ready made
49	Keel adaptor set	4	Plastic	Ready made
50	Keel ballast bulb	1	Lead (TOXIC !)	Ready made
51	Retaining pin	2	Steel	1.5 Ø x 15 mm
52	Keel bulb fairing	2	ABS	Vac.-moulded
53	Retaining nut	1	Nickel-plated brass	M2.5
54	Gasket	1	Rubber cord	2.5 mm Ø, overlength
<b>55</b>	<b>Canopy</b>	<b>1</b>	<b>ABS</b>	<b>Vac.-moulded, CNC- trimmed</b>
56	Mast	1	CFRP tube	5 Ø x 4 Ø x 850 mm
57	Mast sleeve	1	Aluminium tube	6 Ø x 5 Ø x 115 mm

58	Mast base	1	Hardwood dowel	4 Ø x 50 mm
59	Main boom bracket	1	Plastic	Ready made
60	Mast plate	1	Plastic	Ready made
61	Main boom swivel bracket	1	Plastic	Ready made
62	Swivel axle	1	Plastic	Ready made
63	Main boom sleeve	1	Plastic	Ready made
64	Main boom	1	CFRP tube	6 Ø x 5 Ø x 205 mm
65	Depressor	1	Aluminium	Ready made
66	Clamp nut	1	Nickel-plated brass	M2.6
67	Annular clamp, large	3	Plastic	Ready made
68	Retaining screw	6	Stainless steel	M2 x 8 mm
69	Retaining nut	2	Nickel-plated brass	M2
70	Jib hanger	1	Plastic	Ready made
71	Masthead fitting	1	Plastic	Ready made
72	Backstay	1	Polyester cord	0.4 Ø x 1100 mm
73	Wire hook	4	Metal	Ready made, shape as plan
74	Shroud	1	Polyester cord	0.4 Ø x 2000 mm
75	Mainsail	1	Polyester film	Ready made
76	Sail batten	3	CFRP strip	Ready made
77	Sticker	6	Textile film	Ready made
78	Mainsail luff stretcher	1	Polyester cord	0.4 Ø x 300 mm
79	Mainsail halyard	1	Polyester cord	0.4 Ø x 200 mm
80	Mast ring	6	Metal	Ready made
81	Sliding sleeve	1	Plastic	3.2 Ø x 2.2 Ø x 4 mm
82	Collet, large	1	Plastic	Ready made
83	Jib boom	1	CFRP tube	4 Ø x 3 Ø x 202 mm
84	Jib boom end-cap	1	Plastic	Ready made
85	Jib boom end-cap, bored	1	Plastic	Ready made
86	Retaining pin	1	Metal	1.5 Ø x 20 mm
87	Jib counterweight	1	Brass	7.8 Ø x 10 mm
88	Jib	1	Polyester film	Ready made
89	Forestay	1	Polyester cord	0.4 Ø x 1000 mm
90	Jib halyard	1	Polyester cord	0.4 Ø x 200 mm
91	Luff stretcher	1	Polyester cord	0.4 Ø x 200 mm
92	Annular clamp, small	1	Plastic	Ready made
93	Collet, small	3	Plastic	Ready made
94	Jib retainer	1	Polyester cord	0.4 Ø x 300 mm
95	Topping lift	1	Polyester cord	0.4 Ø x 900 mm

The Parts List includes components which are not included in the kit; these must be acquired separately.  
As plan = refer to the plan for the exact size and shape.

**The following items are also required (not included in the kit):**

Order No.	Name
4709	X-306 FM ECO-SPORT SYSTEM (40 MHz) RC set Other Graupner FM radio control systems with three or more channels may also be used.
5125.LOSE	C 261 servo (two required), as rudder and jib trim servo
4103.LOSE	C 5077 servo, as sail-setting servo
or	
5120.LOSE	C 3341 servo, as sail-setting servo
or	
3900.LOSE	C 3241 servo, as sail-setting servo
2585	Graupner 4N-600 AA 2/3 NiMH, as model's power supply

**Replacement parts**

Order No.	Name
2014	Set of CNC-trimmed vacuum-moulded parts (hull, deck, canopy, keel / mast socket)
2015	Keel fin, glass fibre reinforced plastic, with M2.5 retaining pin and adaptor set
2016	Rudder, glass fibre reinforced plastic, with 3 mm Ø shaft
2017	Keel ballast bulb, lead, weight approx. 370 g
2018	Upgrade sail set: high-quality, water-repellent, distortion-free plastic material